

CONTENTS

Page	Rule
2	1 <u>GENERAL</u>
2	2. <u>ADMINISTRATION</u>
2	2.1 English language
2	2.2 Builders
3	2.3 International Class Fee
3	2.4 Registration and measurement certificate
4	2.5 Measurement
4	2.6 Measurement instructions
5	2.7 Identification marks
6	2.8 Sponsorship
6	3 <u>CONSTRUCTION AND MEASUREMENT RULES</u>
6	3.1 General
6	3.2 Hull
6	3.2.1 Materials - GRP
7	3.2.2 Hull measurement rules
10	3.2.3 Hull construction details - GRP
12	3.2.4 Hull construction details - Wood and Wood/Epoxy (See Appendix A, p 24)
12	3.2.5 <i>Not used</i>
12	3.2.6 Fittings
13	3.2.7 Buoyancy
14	3.2.8 Weight
14	3.3 Daggerboard
14	3.3.1 Materials
14	3.3.2 Shape
15	3.4 Rudder and Tiller
15	3.4.1 Materials
16	3.4.2 Shape
16	3.4.4 Definition of Rudder elements
17	3.5 Spars
17	3.5.1 Materials
17	3.5.2 Mast
18	3.5.3 Boom
19	3.5.4 Sprit
19	3.5.5 Running rigging
20	4 <u>ADDITIONAL RULES</u>
5	(spare rule number)
21	6 <u>SAIL</u>
21	6.1 General
21	6.2 Mainsail
6.3	Spare rule number
6.4	Spare rule number
22	6.5 Class Insignia, Nat. Letters, Sail Numbers and Luff Measurement Band
23	6.6 Additional sail rules
24	APPENDIX A: Rules specific to Wood and Wood/Epoxy hulls.
27	PLANS. Index of current official plans.
28	SAIL PLAN

1 **GENERAL**

- 1.1 The object of the class is to provide racing for young people at low cost.
- 1.2 The Optimist is a One-Design Class Dinghy. Except where these rules specifically permit variations, boats of this class shall be alike in hull form, construction, weight and weight distribution, rigging spars and sail plan.
Note: In deciding whether an item is permitted it should be noted that, in a One-Design Class, unless the rules specifically state that something is permitted it shall be assumed to be prohibited.
- 1.3 These rules are complementary to the plans, measurement forms and measurement diagrams. Any request for interpretation and resolution thereof shall be made in accordance with current ISAF regulations.
- 1.4 In the event of discrepancy between these rules, the measurement form and/or the plans the matter shall be referred to the ISAF.

2 **ADMINISTRATION**

2.1 **English Language**

- 2.1.1 The official language of the class is English, and in the event of a dispute over interpretation the English text shall prevail.
- 2.1.2 The word "shall" is mandatory and the word "may" is permissive.
- 2.1.3 Wherever in these rules the words "class rules" are used they shall be taken as including the plans, diagrams and the measurement forms.
- 2.1.4 The "National Class Association" is the International Optimist Class Association in the country concerned.

2.2 **Builders**

- 2.2.1 The Optimist may be built by any professional or amateur builder.
- 2.2.2 Professional builders shall be responsible for supplying boats complying with the class rules. The builder shall at his own expense correct or replace any boat which fails to pass measurement, due to an omission or error by the builder, provided that the boat is submitted for measurement within twelve months of purchase.
- 2.2.3 Manufacturers of kits or parts shall be responsible for supplying parts, which, when assembled in accordance with the manufacturer's instructions (if any), will produce boats complying with the class rules. The manufacturer of the kit or parts which is shown not to do this shall, at his own expense, replace the parts of the kit which are incorrect provided that the error is made known to the manufacturer not more than twelve months from the date of purchase.
- 2.2.4 A builder shall issue with each hull a written builders declaration, stating that the hull complies with the relevant Class rules.

2.3 International Class Fee

- 2.3.1 The International Class fee is US \$16.50 or its equivalent in other currencies, of which \$5.85 is due to ISAF, \$7.45 to IODA and \$3.20 to the National Association.
- 2.3.2 The amount of the International Class Fee is determined by the ISAF in consultation with IODA. The Executive Committee may alter this amount following consultation with the ISAF.
- 2.3.3 The International Class Fee shall be paid by the builder on each hull as soon as building or moulding commences. For wood and wood/epoxy hulls the plaque shall be supplied at the time of measurement.
- 2.3.4 The builder shall buy the building plaque and Registration Book:
(a) for GRP hulls, from IODA
(b) for wood and wood/epoxy hulls, from IODA or the National Optimist Association
- 2.3.5 (a) IODA is responsible for collecting the International Class Fee on behalf of the ISAF.
(b) IODA will buy from ISAF building plaques at \$5.85 each.
(c) IODA or the National Association shall sell the plaques to the builder for \$16.50 each. If IODA sells the plaque to the builder, IODA shall then remit \$3.20 to the National Association.
Each plaque shall, at every stage, be sold with the official International Class Fee receipt and the builders declaration form. The International Class Fee receipt shall be sent to the appropriate National Authority when the boat's sail number is applied for.
- 2.3.6 For each International Class Fee paid IODA or the National Optimist Association shall issue a builders declaration, ISAF International Class Fee receipt and an ISAF plaque, which the builder shall deliver with the hull to the owner. Builders declarations and International Class Fee receipts are only valid if they are made out on the official forms issued by IODA. The building fee receipt and builders declaration is incorporated in the Registration Book.

2.4 Registration and Measurement Certificate

- 2.4.1 No boat is permitted to race in the class unless it has a valid measurement certificate.
- 2.4.2 Each National Authority shall issue sail numbers which shall be consecutive and the number shall be preceded by the national letters. Numbering may restart at 1 on reaching number 9999. A National Authority shall issue a sail number only on receipt of evidence that the building fee has been paid.
- 2.4.3 The certificate is obtained as follows:
- (a) The builder shall have the hull measured by a measurer officially recognised by his National Authority. The Registration Book with the ISAF International class fee receipt, builders declaration and hull measurement form section completed shall be supplied to the owner of the boat.
- (b) The owner shall apply to the appropriate National Authority for a sail number enclosing their Registration Book with builders declaration and building fee receipt. The National Authority shall enter the sail number in the Registration Book.
- (c) The owner is responsible for sending the Registration Book with the builders declaration and all measurement form sections completed to his National Authority, together with any registration fee that may be required. On receipt of this the National Authority shall complete the measurement certificate section of the Registration Book and return it to the owner. Note that where a National Authority prefers to issue its own certificate this shall be firmly fixed to, and mentioned in the Registration Book.

- 2.4.4 Change of ownership invalidates the measurement certificate but shall not necessitate remeasurement. The new owner shall apply to his National Authority for endorsement of the certificate/ Registration book returning it with any re-registration fee required and stating the necessary particulars. The measurement certificate/ Registration book shall then be returned to the owner. If a replacement Registration book is required, it may be obtained from IODA by returning the old Registration book. The new Registration book shall be printed with the same plaque number as the old Registration book.
- 2.4.5 Notwithstanding anything contained in these rules, the ISAF or the National Authority shall have the power to refuse to grant a certificate to, or withdraw, a measurement certificate from any boat, giving written reasons for taking such action.
- 2.4.6 In countries where there is no National Authority or in which the National Authority does not wish to administer the class, its functions as stated in these rules shall be carried out by IODA or its delegated representatives (i.e. National Class Association).

2.5 Measurement

- 2.5.1 Only a measurer officially recognised by a National Authority shall measure a hull, spars, sails and equipment, and sign the declaration on the measurement form that they comply with the class rules. Hulls shall be measured in accordance with the appropriate hull measurement instructions. For wood and wood/epoxy hulls see Appendix A
- 2.5.2 The measurer shall report on the measurement form anything which he considers to be a departure from the intended nature or design of the boat or to be against the general interest of the class. A measurement certificate may be refused, even if the specific requirements of the rules are satisfied.
- 2.5.3 A measurer shall not measure a hull, spars, sails, or equipment owned or built by himself, or in which he is an interested party or has a vested interest.
- 2.5.4 For wood and wood/epoxy hulls, see Appendix A.
All GRP hulls shall comply with the current rules or the rules current at the time the boat was first measured and registered with the National Authority as the bona fide property of a current Optimist sailor or his family, (with no family being permitted to register more than two Optimists per sailor) or a sailing club/school recognised by the national authority or national Optimist association .
GRP hulls first so measured and registered between 1 March 1995 and 1 March 1996 shall conform either to the Class Rules in force from 1 March 1994 or to the Class Rules in force from 1 March 1995. Hulls first so measured and registered after 1 March 1996 shall conform to the class rules then current.
Fittings, spars, sails and other equipment shall comply with the current rules, unless otherwise stated in the specific class rule referring to such equipment.
- 2.5.5 It is the owner's responsibility to ensure that his hull, spars, sails and equipment are maintained in accordance with the class rules so that the measurement certificate is not invalidated. Alterations or replacements to the hull, sails, spars and equipment shall comply with the current rules.
- 2.5.6 New or altered sails shall be measured by a measurer who shall stamp or sign and date the sails near the tack. The details shall be recorded on the certificate and the entry signed by the measurer or the secretary of the National Authority.

2.6 Measurement Instructions

Except where varied by these rules the ISAF Measurement Instructions shall apply.

2.7 Identification Marks

2.7.1 The Class Emblem shall be the letter I and O and shall conform in shape and size to the pattern held by the ISAF. Copies may be obtained from the National Class Associations, IODA or National Authority.

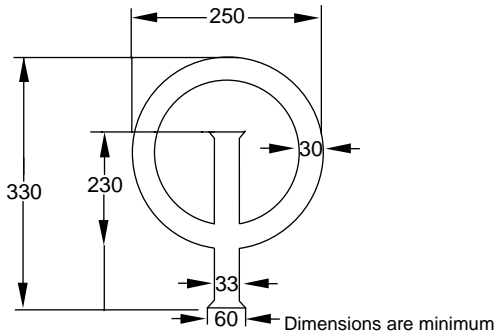

2.7.2 The building fee plaque shall be legible, clearly shown and permanently glued on the starboard side of the aft face of the mast thwart bulkhead.

2.7.3 All hulls, shall have the sail number and National Letters clearly shown on a plate firmly fixed to the starboard side of the aft face of the mast thwart bulkhead in figures not less than 10mm high.

2.7.3.1 GRP hulls shall have an identification number, in figures not less than 10 mm high, moulded in each hull component:

Component 1: Hull shell: the forward face of the forward transom (within 60 mm of the centre of this transom).

Component 2: Gunwale - Mast Thwart assembly: the starboard bottom flange of the mast thwart bulkhead.

Component 3: Daggerboard Case - Midship Frame assembly: the forward bottom flange of the daggerboard case.

This identification number shall consist of : code number of builder and code number of mould, both allocated by IODA to each mould and builder following approval of each prototype. This number may be invalidated if it is established that hulls have deviated from class rules after prototype measurement.

Example of a possible hull identification no.: (this example no. is not valid)

004N9022804 H

2.7.3.2 On GRP hulls the builder shall engrave on the forward transom, 15mm below the identification number a registration mark, in figures not less than 6 mm high. This registration mark shall consist of:

Year	ISAF plaque fee number
------	------------------------

2.7.3.3 Manufacturers shall allot a serial number to the mast, boom, sprit, daggerboard and rudder. These serial numbers shall be reported on the appropriate Measurement Form by the measurer and shall be clearly and indelibly marked by the builder on the rudder, daggerboard and spars.

- 2.7.4 The sail number and National Letters shall be clearly marked on the rudder, daggerboard and spars.
- 2.7.5 The sail shall carry identification marks indicated in rule 6.5 and each sail manufactured or measured after January 1st 1990 shall have permanently fixed near its tack an officially numbered sail button. No sail shall be accepted for its first measurement without a sail button. Buttons shall not be transferred from one sail to another. Buttons shall normally be obtained from the International Optimist Dinghy Association (IODA) by the sailmakers, but may also be obtained, if necessary, by National Class Associations.
- 2.7.6 All emblems, plaques, marks and numbers shall be clearly legible, of durable material and shall be securely attached.

2.8 **Sponsorship**

The Optimist Class is Category A in accord with the ISAF Advertising Code.

3 **CONSTRUCTION AND MEASUREMENT RULES**

3.1 **General**

- 3.1.1 All boats shall be built according to the class rules,(see also CR 2.1.3). The dimensions and shape of the hull shall be as shown on the plans and as given in these rules, diagrams and measurement forms and shall conform with the tolerances stated therein.
- 3.1.2 Any attempt to concentrate the weight of the hull is prohibited.

3.2 **Hull**

3.2.1 **Materials - GRP.**

For CR 3.2.1 for wood and wood/epoxy hulls, see Appendix A.

- 3.2.1.1 The hull shall be constructed of materials approved by the ISAF. The following are the currently approved materials: Glass Reinforced Plastic (GRP).
- 3.2.1.2 Hulls shall be constructed from:

Mat 300 (+/- 10%) Mat 450 (+/- 10%)	Chopped strand mat of E glass fibres
Woven Cloth or Biaxial 280 (+/-10%)	Cloth of woven or otherwise biaxial applied skeins of continuous E glass fibres
Resin.	Polyester resin for GRP lamination.
Bonding agent	Of any material to bond hull components and backing plates where appropriate.
Gel coat	May be of any colour
Paint	May be of any colour
Foam core 13/60 (+/-10%)	Durable, non-absorbent closed cell PVC foam which shall be bonded to the walls (see also CR 3.2.3.2)

Mats & woven cloth are specified in grams per square metre +/- 10% (gr./m²)
The E glass fibres and Polyester resin shall be transparent. Coloured fibres and resins are prohibited.

Foam core is specified in thickness and weight per cubic metre +/- 10% (mm/kg/m³)
 No material other than those prescribed above shall be used to build hulls. In case of doubt the IODA and the ISAF may prescribe any tests and investigations at builder's expense. (see also CR 3.2.3.2)

3.2.2 Hull Measurement Rules (see also CR 3.1)

For GRP hulls the ISAF or IODA will require samples of the hull laminates to check compliance with the Class Rules. A builder shall permit an approved measurer or class representative to inspect work at any time during production of hulls.

3.2.2.1 GRP Hulls. For wood and wood/epoxy hulls, see Appendix A.

Unless otherwise prescribed in these Class Rules, plans and measurement forms, tolerances shall be +/- 2mm. Measurements prescribed as max. (=not more than) or min. (=not less than) shall have no further tolerances.

Some tolerance examples (all measurements in mm.):

XYZ co-ordinate: 1037/008/35.3 i.e. all standard tolerances +/-2. (1035-1039/006-010/33.3-37.3).

Dimension: 40. i.e. standard tolerance +/-2. (38-42)

XYZ co-ordinate: 2158 +/- 4/000/172 i.e. X co-ordinate 2158 +/- 4 (2154-2162), Y co-ordinate 000 and Z co-ordinate 172 have standard tolerance +/- 2.

XYZ co-ordinate (1037/008/35.3) +/- 4 i.e. all co-ordinates +/- 4

Dimension: 40 +/- 3 i.e. 37-43. Dimension 40+4-0 i.e. 40-44

The tolerances on hull measurements are intended to allow for genuine building errors and for subsequent distortion only and shall not be used to deliberately alter the design shape.

3.2.2.2 GRP Hull Prototype Measurement: It is obligatory for all builders of GRP hulls to ensure that any prototype hull measures correctly before series production commences. Non-professional builders shall ensure that the first hull built in any mould shall be measured as a prototype. Only measurers approved by the ISAF and the IODA shall measure prototypes. (see also CR 2.7.3.1)

3.2.2.3 The Base-line shall be a horizontal line passing through points which are 110mm and 162mm below the outer surface of the hull on its centreline at 28mm and 2121mm respectively from a vertical plane through the lower corner of the aft transom. The upper-base-line shall be a horizontal centreline passing through points which are 63 mm above the highest point of the aft transom and 23 mm above the highest point of the forward transom.

3.2.2.4 The aft transom shall be at right angles to the base line but a maximum deviation of 5mm, measured at the upper edge of the transom is permitted.

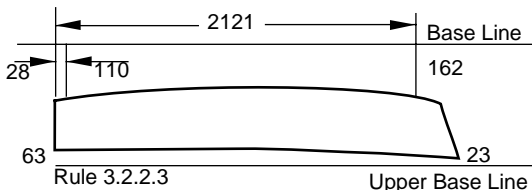

Note: Hull is shown inverted

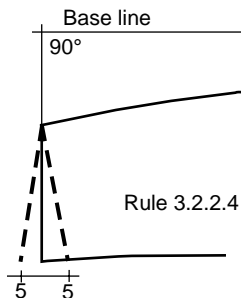

- 3.2.2.5 GRP Hulls. For wood and wood/epoxy hulls, see Appendix A. The overall length excluding rudder fittings, shall be 2302mm +/- 7mm, measured at point 4. For length and beam measurements, points 4 (sheerline) shall be defined by using the 'Standardized Sheerline Finder'.
- 3.2.2.6 A straight edge long enough to span the bottom panel from chine to chine placed at any point on the panel at right angles to the fore and aft centreline shall nowhere be more than 5 mm from the surface of the panel. No hollows are allowed
- 3.2.2.7 A straight edge placed anywhere in contact with the side panel and spanning the panel and so angled that it lies as close as possible to the panel shall nowhere be more than 5mm from the surface of the panel.
- 3.2.2.8 A straight edge 300mm long placed anywhere on the bottom panel parallel to the fore and aft centreline of the boat shall nowhere be more than 4mm from the surface of the bottom panel. No hollows are allowed. A straight edge 150mm long, placed in the same way, shall nowhere be more than 2mm from the bottom panel.

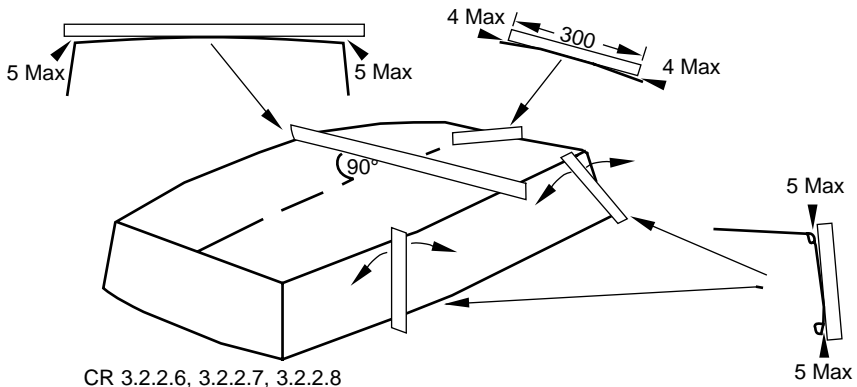

CR 3.2.2.6, 3.2.2.7, 3.2.2.8

On GRP hulls only, for the purpose of this and other 'panel flatness measurements' the extent of the panels will be limited by an edge zone, defined by the 'Standardized Edge-Zone Finder'.

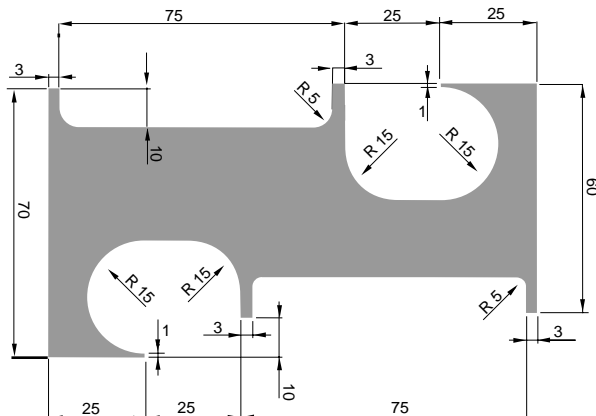

Standardized Edge-Zone and Sheerline Finder (CR 3.2.2.8)

- 3.2.2.9 GRP Hulls. For wood and wood/epoxy hulls, see Appendix A. The forward and aft transoms, mast thwart bulkhead, midship frame aft face and daggerboard case (vertical) sides shall be flat with not more than 5mm tolerance. The top sides of the mast thwart, daggerboard case and midship frame shall be flat +2-0 mm (i.e no hollows allowed)
- 3.2.2.10 GRP Hulls. For wood and wood/epoxy hulls, see Appendix A. The inside length of the daggerboard slot and of the slot in the bottom panel shall be 330 +/-4 mm. The vertical ends in the daggerboard slot shall be square to the base line. At each end a rake to taper not exceeding 4mm is permitted. The daggerboard case top side, measured at the top edges of the ends of the daggerboard slot, shall be parallel to the upper base line, within a tolerance of 5 mm maximum.
- 3.2.2.11 GRP Hulls. For wood and wood/epoxy hulls, see Appendix A. The inside width of the daggerboard case slot shall be 17 mm +/- 1 mm. The fore and aft ends of the slot shall be semi-circular in cross section. (See also CR 3.2.6.1)
- 3.2.2.12 GRP Hulls. For wood and wood/epoxy hulls, see Appendix A. The outside edges of the hull between the bottom and side panels, between the bottom and forward transom, and between the side panels and forward transom shall be rounded to a radius of 10 mm +0-1. At the aft transom side and bottom outside edges no radius is permitted.
- 3.2.2.13 The mast hole in the thwart shall be approximately circular. The diameter is optional but shall not vary by more than 3mm in any direction. A sleeve of any material may be fitted in the hole to limit abrasion. The sleeve shall not extend more than 3mm above the mast thwart. The total height of the sleeve shall not exceed 30mm and its hole shall comply with the requirements of this rule

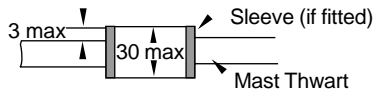

CR 3.2.2.13



- 3.2.2.14 Except as specified in these Class rules or plans, holes or cut outs in the gunwale, daggerboard case, midship frame, mast thwart and bulkhead are prohibited. (see also CR 1.2)
- 3.2.2.15 GRP Hulls.

To avoid sharp projections and injuries, the exposed edges of: the gunwale and rubbing strake, midship frame top flange, daggerboard case opening, mast thwart and mast thwart bulkhead opening; shall be rounded to the maximum possible radius.

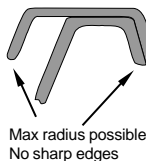

CR 3.2.2.15

- 3.2.2.16 GRP Hulls. For wood and wood/epoxy hulls, see plans
The Gunwale-Rubbing strake section is defined perpendicular* to the sheerline. its positioning angle is fixed and related to the base line reference surface only. The Gunwale section shall be constant throughout its entire length, including the Forward and Aft transom, except within 180 mm of the intersection between Transom and Side sheerlines. The Rubbing strake section shall be constant throughout its entire length, including the Forward and Aft transom, except within 10 mm of the intersection between Transom and Side sheerlines. (*If sheerline is curved, perpendicular = along the radius of the sheerline curve)
- 3.2.3 GRP Hull Construction Details See also CR 3.2.2
For wood and wood/epoxy hull construction details, see Appendix A
- 3.2.3.1 GRP Moulds.
Hulls shall be constructed of only three moulded components as described in CR 2.7.3.1. Each of these three components shall be constructed using only one mould. Builders shall apply for a mould identification number allocated by the IODA for each mould. (see also CR 2.7.3.1 & 2.7.3.2)
- 3.2.3.2 Laminate specifications. (see also CR 3.2.1.2)
- Laminate specification and lay up order shall be as defined in these Class rules, details and plans.
 - Distribution of glass content and weight of each laminate shall be uniform throughout within +/- 5%.
 - Thickness of laminate shall be uniform throughout within +/- 5% or 1mm whichever is greater.
 - Thickness and density of foam core in the bottom and the mast thwart laminate shall be uniform throughout within +/- 3%.
 - For the purpose of building efficiency, overlapping of 1 mat, woven cloth or biaxial is permitted within 50mm. from any corner. Overlapping, if any, shall be applied over the full length along each corner.
 - Any laminate shall only have one mould side, which shall be smooth.
 - Moulded patterns are not permitted except for an optional anti-slip pattern not exceeding 1mm thickness at the gunwale aft of the midship frame.

Laminate specifications and lay-up order details:

(a) Bottom laminate	Thickness : max 19mm
	Mould side gel coat
	300 mat
	300 mat
	450 mat
	Foam core 13/60
	450 mat
	300 mat
	Painted coat on the entire surface of the exposed inner bottom
	A patch or patches of anti-slip paint (total surface not less than 0.50 m ²) on the exposed inner bottom aft of the midship frame, but not closer than 250 mm to the aft transom.

(b) Sides and transoms laminates, incl. rubbing strakes	Thickness : max 4mm
	Mould side gel coat
	300 mat
	450 mat
	450 mat
	280 woven cloth or biaxial
Painted coat optional	
(c) Daggerboard slot laminate	Thickness : min 4mm/max 8mm
	Mould side gel coat
	300 mat
	min 2 x 450 mat/max 5 x 450 mat
	300 mat
	Painted coat optional
(d) Daggerboard case-midship frame assembly, except flanges and top of daggerboard case laminate	Thickness : min 4mm/max 8mm
	Mould side gel coat
	300 mat
	min 3 x 450 mat/max 6 x 450 mat
	Painted coat optional
(e) Mast thwart laminate	Thickness : max 17mm
	Mould side gel coat
	300 mat
	300 mat
	300 mat
	Foam core 13/60
	450 mat
	Within 50mm of the mast hole min 3/max 5 additional layers of 450 mat may be used as local reinforcement.
	Painted coat optional.
(f) Mast thwart bulkhead laminate except flanges	Thickness : max 4mm
	Mould side gel coat
	300 mat
	450 mat
	450 mat
	Painted coat optional.

For the purpose of positioning and fixing, the top of the daggerboard case, the flanges of the midship frame-daggerboard case assembly and the flanges of the mast thwart bulkhead shall consist of min 3 x 450/ max 5 x 450 mat (min 3mm/max 8mm thickness). At this top and these flanges, the distribution of glass content and the thickness of the laminate need not be uniform throughout..

(g) Gunwale laminate, incl. rubbing strake.	Thickness : max 4mm
	Mould side gel coat
	450 mat
	450 mat
	450 mat
300 woven cloth as supporting reinforcement between inner hull sides and inner gunwale (see GRP plan sheets 3), except forward of the mast thwart bulkhead. Gaps of up to 55mm wide are permitted at the aft corners, at each side of the side members and at the aft side of the mast thwart bulkhead. The width of this reinforcement shall be 50 +/- 5mm.	

3.2.4 **Construction Details - Wood: See Appendix A**

3.2.5 *Rule no. not used.*

3.2.6 **Fittings**

3.2.6.1 The following fittings are permitted:

- (a) 2 Mainsheet blocks (excluding those on the boom) shall be attached to the hull inner bottom. The centre of their fixing points shall be at 786 +/- 5 and 894 +/- 5 from the forward face of the aft transom.
- (b) One ratchet block for the mainsheet.
- (c) 2 toe-straps and 4 associated fixing plates of 50 +/- 10mm x 20 +/- 5mm x 2 +/- 1mm if metal or 50 +/- 10mm x 20 +/- 5mm x 9 +/- 1mm if plastic. (see also CR 3.2.6.2 and CR 3.2.7.3)
- (d) A compass and associated fixings, which shall all be removable for weighing the hull. Digital compasses and/or devices memorising, correlating or transmitting data relative to wind direction or speed, or boat speed or direction and location are not permitted.
- (e) Retaining clip(s) for a paddle.
- (f) An adjustable mast step. Movement of the mast at the mast step or at the passage of the mast through the mast thwart shall not be able to exceed 3mm in any horizontal direction. The mast or mast step shall not be adjusted while racing. Mast step devices which can be easily set while racing in such a way that this class rule is infringed, are prohibited.
- (g) Retaining clips for water bottles, food container or other personal equipment, which shall be removable for weighing the hull.
- (h) Retaining clip for fastening the tiller extension to the tiller.
- (i) Strips of non-metallic material may be fitted in the daggerboard slot within 30mm of the top and the bottom of the slot to achieve a uniform opening of 16mm +/- 2mm at the top and the bottom of the slot. Additional non-metallic material may be placed within 30mm of each end of the top and bottom of the slot to act as positioning and protection of the daggerboard. This additional material shall be removed upon request of the measurer, for the measurement of the slot. (see also CR 3.2.2.11)
- (j) A handle or ball may be used on the outer end of:
 - (i) Sprit halyard.
 - (ii) Boom downhaul.

- (k) 1 hole (diameter max 8 mm.) on the centre line in the top of the forward gunwale just after the forward transom, for drainage and or for leading (not fixing) of the painter line, 1 hole (diameter max 8 mm.) on the centre line in the top of the aft gunwale just before the aft transom, for drainage and or for fixing of an optional shock-cord to tension the toe straps. (see also 4.3), 1 hole (diameter max 8 mm.) on the centre line in the daggerboard case top side, aft of the daggerboard slot, for drainage.

- 3.2.6.2 Backing plates, when used in GRP boats, shall comply with the Plans and laid-in as shown on this diagram. (i.e. top surface of backing plate flush with top of bottom foam core) Toe straps can be attached to the midship frame, using at most 4 fixing plates (two for each strap) of maximum dimensions of 50 +/- 10mm x 20 +/- 5mm x 2 +/- 1mm for

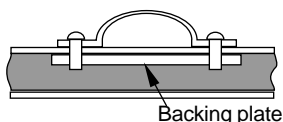

CR 3.2.6.2

metal plates or 50 +/- 10mm x 20 +/- 5mm x 9 +/- 1mm for plastic plates.

- 3.2.6.3 The following items, and others not specifically permitted by these rules, are prohibited:
- Mainsheet cleats, mainsheet horse, track or traveller.
 - Suction bailers and bilge pumps.
 - Decking or spray covers of any sort.
 - Any apparatus or contrivance outboard, or extending outboard, which is, or may be used to assist in supporting the helmsman outboard.

3.2.7 Buoyancy

- 3.2.7.1 The hull shall be fitted with three buoyancy units in the form of inflated air bags made of strong fibre-reinforced material. Each unit shall be 45 +/- 5 litres. Each unit shall be equipped with a fill valve that positively prevents the accidental release of air (i.e.- Non-return valves and threaded valves with screw-on caps). The minimum weight of each unit shall be 200 grams.
- 3.2.7.2 One unit shall be placed along the whole width of the aft transom and one unit shall be placed along each side between the midship frame and the mast thwart bulkhead.

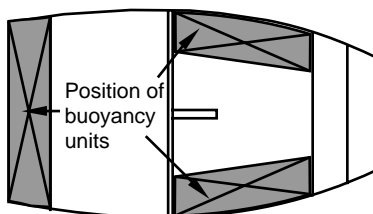

CR 3.2.7.2

- 3.2.7.3 Buoyancy units shall be securely fastened to the hull by three straps for each unit, each strap shall be 45 mm +/- 6 wide. 1 backing plate in GRP boats of metal 50 +/- 10mm x 20 +/- 5mm x 2 +/- 1mm and 1 fixing plate, 50 +/- 10mm x 20 +/- 5mm x 2 +/- 1mm if metal or 50 +/- 10mm x 20 +/- 5mm x 9 +/- 1mm if plastic, shall be used for fastening of each strap. At the aft transom centre strap a bigger plate 50 +/- 10mm x 50 +/- 10mm x 2 +/- 1mm if metal or 50 +/- 10mm x 50 +/- 10mm x 9 +/- 1mm if plastic for combined use with the toe-strap shall be used.
- 3.2.7.4 The owner is responsible at all times for the buoyancy and for ensuring that at intervals of not more than 12 months the buoyancy is tested and the measurement certificate endorsed by a measurer or a responsible club officer. The measurement certificate shall not be valid until so endorsed.

3.2.7.5 The measurer shall witness a buoyancy test as follows:
The boat shall be swamped with water and with iron weights of not less than 60kg placed aft of and within 100mm of the midship frame, it shall float with the gunwales clear of the water. The measurer shall make sure that the buoyancy and its fastening are sound, and that inflatable buoyancy shows no visible signs of deflation.

3.2.7.6 The first buoyancy test shall normally be completed at the time of the first measurement of the boat. However, if the measurer certifies that the buoyancy test could not be taken at that time, but in all other respects the class rules are satisfied the measurement certificate may be issued but with the endorsement "Not valid until a buoyancy test has been passed."

3.2.8 Weight

3.2.8.1 The weight of the hull in dry condition, including: rudder gudgeons fixed to the aft transom, buoyancy straps , toe straps and associated fixings (without removable foam or protection), mast step, block fittings permanently attached, but excluding: corrector weights, blocks, mainsheet, buoyancy air bags, painter, bailer, paddle, compass (with bracket if any) and fixings, retaining clips for water bottles, food containers or other personal equipment and fixings, and all other not specifically permitted items, shall not be less than 32kg.

3.2.8.2 If the weight of the hull in the same condition as prescribed in CR 3.2.8.1 but including buoyancy air bags is less than 35kg but not less than 32.6 kg wood corrector weights shall be fitted to bring the hull weight up to not less than 35kg. The corrector weights shall be permanently fitted, half to the forward transom and half to the aft transom. No corrector weights shall be removed or altered without the boat being re-weighed by an official measurer. The weight of each corrector shall be stamped or otherwise marked on the corrector and endorsed on the measurement certificate.
(See also CR 3.2.7.1 for minimum weight of buoyancy air bags.)

3.3 Daggerboard

3.3.1 Materials

3.3.1.1 The daggerboard shall be made of :

Wood	Ply or laminated
GRP	
Resin	Of any kind. Shall not be coloured
Glass fibre	Of any kind. Shall not be coloured
Foam. Shall only be used as core material	Non-absorbent closed cell of any kind
Bonding agent	Of any kind and colour
Filler	Of any kind and colour
Gelcoat or paint	Of any kind and colour

3.3.1.2 Non-metallic reinforcement (bushing) of diameter not more than 20mm may be used around screws, rivets or bolts.

3.3.2 Shape

3.3.2.1 The daggerboard shall be generally a rectangular flat plate in shape, except that the lower corners may be rounded to a radius of not more than 32mm, and the upper corners to a radius of not more than 5mm.

- 3.3.2.2 The thickness of the daggerboard (excluding bevels) shall be not less than 10mm nor more than 14mm. Beveling is permitted between the edges and the beveling limits, situated 60mm from all edges. The thickness of the daggerboard between the beveling limits shall nowhere vary by more than 0.5mm.
- 3.3.2.3 The overall length of the daggerboard shall not be more than 1067mm and the width not more than 290mm nor less than 275mm. Within these limits, the width shall not vary by more than 3mm.
- 3.3.2.4 The daggerboard shall be fitted with stop battens, one each side of the top of the board. Permitted materials are the same as for the daggerboard. The battens shall extend over the full width of the board, and the depth shall not be less than 35mm throughout. The thickness of the assembled stop battens and daggerboard shall be not less than 40mm. The exposed edges of the battens may be rounded to a radius of not more than 5mm. The battens may be fixed with glue, and/or not more than two bolts of 10mm diameter, or not more than the equivalent weight in smaller bolts, pins, rivets or screws. The length of these fasteners shall not exceed the thickness of the assembled daggerboard and stop battens. Alternatively, the battens may also be constructed as an integral part of the daggerboard.
- 3.3.3 The weight of the daggerboard, without attachment or positioning features, shall be not less than 2.0kg. Ballasting or cut-outs of the daggerboard are prohibited. The centre of gravity of the assembled daggerboard and stop battens shall not be less than 520mm away from the lower edge.
- 3.3.4 The daggerboard shall float, and shall be attached to the boat. One hole may be drilled through the daggerboard and the battens in any place. Its diameter shall not exceed 10mm. An elastic cord or lanyard may be used to attach the daggerboard to the hull. A small shackle may be used to attach the cord or lanyard, either to the hull or to the daggerboard.
- 3.3.5 The daggerboard may be held in the daggerboard case by a loop of (elastic) cord. The cord may be fixed to the daggerboard case through two eyes or to the mast thwart bulkhead through two holes, with a diameter of not more than 10mm. The position of the eyes or holes is optional.

3.4 Rudder and Tiller

3.4.1 Materials

- 3.4.1.1 The rudder shall be made of:

Wood	Ply or laminated
GRP	
Resin	Of any kind. Shall not be coloured
Glass fibre	Of any kind. Shall not be coloured
Foam. Shall only be used as core material	Non-absorbent closed cell of any kind
Bonding agent	Of any kind and colour
Filler	Of any kind and colour
Gelcoat or paint	Of any kind and colour

- 3.4.1.2 The tiller and tiller extension may be made of any material.

- 3.4.1.3 Non-metallic reinforcement (bushing) of diameter not more than 20mm may be used around screws, rivets, or bolts.
- 3.4.2 Shape
- 3.4.2.1 The rudder shape is optional, but excluding the rudder fittings, it shall be capable of being laid within a rectangle of 750mm x 260mm. The rudder head is defined to be that part of the rudder located within a distance of 300mm from the upper edge of the rectangle. The rest of the rudder is the rudder blade.
- 3.4.2.2 The thickness of the rudder blade (excluding bevels) shall be not less than 10mm and not more than 14mm. Beveling is permitted between the edges and the beveling limits, situated 60mm from all edges. The thickness of the rudder blade between the beveling limits shall nowhere vary by more than 0.5mm.
- 3.4.2.3 The tiller, tiller extension and associated fittings may be of any type, but they shall have no sharp projections.
- 3.4.2.4 The tiller and tiller extension shall each be not more than 750mm long and their combined length shall not be more than 1200mm.
- 3.4.2.5 Any part of the tiller which is aft of the rudder head frontline (see Class Rules 3.4.4 for definition) or its extensions shall be included in the rectangle (as defined in 3.4.2.1).
- 3.4.3 The assembled rudder, tiller and tiller extension shall float, and their total weight shall not be less than 1.5kg. Ballasting of any part of this assembly is prohibited.
- 3.4.4 Definition of Rudder elements
- 3.4.4.1 Bearing lines: two horizontal lines (parallel to the baseline) through the bearing points of the rudder fittings.
- 3.4.4.2 Rudder head front line: line passing through the intersections of the forward edge of the rudder and the two bearing lines.
- 3.4.5 Fixing and positioning:
Boats built before 1 March 1992 may either use the rudder positioning method which was applicable at the time of building, or the current one. The positioning fittings of the rudder themselves shall then comply with the correspondingly dated rules for the rudder.
- 3.4.5.1 Two pintles shall be fixed on the rudder, their diameter shall be not more than nominal 6mm. The distance between the upper edge of the tiller and the bearing line of the upper pintel shall be not less than 85mm, measured along the rudder head frontline. Two gudgeons shall be fixed to the aft transom, with holes not less than 6mm diameter. The distance between the bearing lines of the two gudgeons shall be not less than 200mm. The corresponding distance between the pintles shall be not more than 200mm. The depth of the pivoting holes in the two gudgeons shall not exceed 5mm, and the distances from those holes to the aft face of the aft transom shall not differ by more than 2mm.
- 3.4.5.2 The rudder and tiller assembly shall be fitted to the aft transom so that it does not become detached from the hull during a capsize. To this effect, an appropriate retaining clip/spring shall be fitted on the forward edge of the rudder head, not less than 5mm below the bearing line of the upper pintel.

3.4.5.3 When fitted to the aft transom, the distances from the rudder head front line to the aft face of the aft transom, measured at the position of both bearing lines, shall be not more than 45mm and shall not differ by more than 2mm.

3.5 Spars

3.5.1 Materials

3.5.1.1 The spars shall be made of either, aluminium alloy tube or, of solid wood. Wooden spars shall be of not more than two pieces of wood. Any exploitation of tolerances in order to achieve non-circular, tapered or otherwise variable spars, is prohibited. The wall thickness of the aluminium alloy tubing shall be constant throughout the spars. Internal sleeves, ribs and stiffening are prohibited.

3.5.1.2 Plastic, wood or metal may be used for end caps and fittings including the boom jaws. End caps, sprit end and jaws fittings shall be permanently fixed but may be glued to the spars. The length of the fittings and cap shall not exceed 100 mm for the lower end of the mast, the outboard end of the boom and the jaws fitting, 60mm for the top of the mast and both ends of the sprit. At the top of the mast the height of the visible part of an end cap shall not exceed 10mm.

3.5.1.3 Spars shall be capable of floating approximately horizontally for thirty minutes with no discernible water penetration for a sealed spar or loss of buoyancy for a foam filled spar.

3.5.1.4 Unless specifically permitted by these rules, fittings on spars shall be permanently fixed by means of rivets, screws, and/or nuts and bolts.

3.5.1.5 Non-metallic protective material may be used on either the sprit or mast at the area where they make contact. This material shall not exceed max. 150mm length and max. 1.5mm thickness.

3.5.2 Mast

3.5.2.1 The mast shall be approximately circular in section. At any cross section the diameter shall not vary by more than 3mm. The diameter above 50mm from the heel shall nowhere be less than 44mm.

3.5.2.2 Masts shall be of uniform section above 50mm from the heel. Wooden masts may be reinforced with a GRP or plastic collar which shall extend not more than 800mm above the heel and shall not increase the diameter by more than 4mm.

3.5.2.3 An aluminium mast may be fitted with not more than two collars of GRP or plastic to allow it to fit a larger diameter mast thwart hole and mast step. Each collar shall be of uniform section and shall not extend along the mast for more than 50mm.

3.5.2.4 The overall length of the mast shall be not more than 2350mm.

3.5.2.5 Standing rigging of any sort is prohibited.

- 3.5.2.6 The mast shall have either two holes, in any direction in the horizontal plane, or two eyes, which need not be permanently fixed, or one eye and one hole. The upper edge of one of the holes or eyes shall be not less than 20mm from the top of the mast and the upper edge of the other not less than 120 mm from the top of the mast. Lacing lines shall pass through these eyes or holes and shall be lashed through the eyelet at the throat of the sail, see also CR. 6.6.3.1 A wind indicator or wind indicator fittings (CR. 3.5.2.12) may secure, or be secured by these lacing lines, but this does not release the lines from the obligation of passing through the holes or eyes.
- 3.5.2.7 Distinctively coloured bands, clearly visible while racing, and each not less than 10mm wide shall be marked on the mast as follows:
- (a) Band No. 1, the lower edge of which shall be not less than 610 mm from the top of the mast.
 - (b) Band No. 2, the upper edge of which shall be not more than 635 mm from the top of the mast.
- The lower edge of Band No. 1 and the upper edge of Band No. 2 shall be permanently marked by a scribed line or not less than two marks made with a centre punch.
- 3.5.2.8 The mast shall be positioned in the mast step by means of wedges, blocks or other devices so that it shall be unable to move more than 3mm in any horizontal direction. The position of the heel of the mast shall not be varied while racing.
- 3.5.2.9 The mast shall have a cleat in a suitable position for securing the boom downhaul.
- 3.5.2.10 The mast shall have, in a suitable position, for the sprit, either a cleat and one hole or eye (which need not be permanently fixed), or a toothed rack.
- 3.5.2.11 A locking device or other arrangement shall be fitted and used to prevent the mast from coming out of its step when the boat is capsized.
- 3.5.2.12 A wind indicator may be fitted to the top of the mast. The mast may have a fitting (which need not be permanently fixed) for securing the wind indicator. Such a fitting shall be positioned within 150mm below the top end of the mast and it shall have no sharp projections. The wind indicator or its attachment fittings may be used to help secure the lacing lines from the throat of the sail.
- 3.5.2.13 The mast may have a pin stop positioned on the forward side of the mast 1680 mm +/- 10mm below the top end of the mast. This pin shall not be more than 8mm diameter and within 10mm of the surface of the mast and shall have no sharp projections.
- 3.5.3 Boom
- 3.5.3.1 The boom shall be approximately circular and of uniform section throughout. The diameter shall be not less than 25mm and at any section it shall not vary by more than 3mm.
- 3.5.3.2 The boom, excluding the boom jaws, shall not exceed 2057mm in length.
- 3.5.3.3 The type of boom jaws and jaws fitting is optional but thickness of the jaws shall not exceed 35mm and the length of the jaws fittings shall not exceed 100mm. A rope may be fastened to the boom jaws or jaws fittings through two holes or through two eyes, and pass forward, around and over a pin positioned on the forward surface of the mast (See also CR 3.5.2.13).

- 3.5.3.4 A distinctively coloured band, clearly visible while racing, and not less than 10mm wide shall be marked on the boom with its forward edge not more than 2000mm from the aft edge of the mast. The inner edge of the band shall be permanently marked by a scribed line or not less than two marks made with a centre punch. The coloured band at the outboard end of the boom may be on a permanently fixed end cap, provided that no visible part of the end cap extends inward of the position of the forward edge of the band, and that the cap complies with the former part of this rule, and with class rule 3.5.3.2.
- 3.5.3.5 Either the boom or the end cap shall have a hole or lacing eye. The forward edge of the hole or the opening of the eye shall be not more than 40mm from the inner edge of the band at the outboard end of the boom.
- 3.5.3.6 A cleat with no sharp projections for securing a clew outhaul may be fitted on the boom. It shall be not less than 400mm from the outer end of the boom.
- 3.5.3.7 The boom downhaul may be attached to the boom in an optional manner by use of a fixed stop or lacing eye at a fixed position. The outer edge of the fitting used shall not be more than 200mm from the inner end of the boom excluding boom jaws.
- 3.5.3.8 The method of attachment of the mainsheet or mainsheet block(s) to the boom is optional (provided they cannot slip along the boom, and the maximum clearance between the span and the boom shall be not more than 100mm, at any position along the boom). The position of the blocks or the length of boom strops shall not be adjusted while racing.
- 3.5.3.9 There shall not be any fitting, rigging or device the purpose of which is, or may be, to control the position of the boom on the mast except for items specifically required or permitted by these rules.
- 3.5.4 Sprit
- 3.5.4.1 The sprit shall be approximately circular and of uniform section throughout. Its diameter shall be not less than 24mm and in any section it shall not vary by more than 3mm.
- 3.5.4.2 The sprit shall be not more than 2286mm in length, including end fittings.
- 3.5.4.3 The type of fitting at the upper end of the sprit shall be as shown in the rigging plan. If the upper end fitting exhibits a widening after an initial narrowing, this widening shall not be in excess of 13mm.
The fitting at the lower end of the sprit shall be either one of the fittings permitted at its upper end, or the sprit may be fitted with an eye, a hook, or it may have a hole through the spar. The length of the end fittings on both ends shall not exceed 60mm. The eye, hook or hole at the lower end of the sprit if present, shall be located within 60mm of this end.
- 3.5.5 Running Rigging
- 3.5.5.1 The mainsheet arrangement is optional except as controlled by CR 3.2.6.1 and CR 3.5.3.8.
- 3.5.5.2 Downhaul. A single part downhaul of rope and/or wire shall be fitted to the boom not more than 200mm from the inner edge of the boom jaws. It shall be secured to a cleat on the mast. The downhaul shall not be adjustable from aft of the midship frame.

- 3.5.5.3 Only the lower end of the sprit shall be made fast to the mast. The only methods of attachment and adjustment of the lower end of the sprit shall be by means of:
- (a) A rope or wire rope loop in conjunction with a toothed rack. The maximum dimensions of the toothed rack are:

Length	150mm
Width	20mm
Thickness	3mm
Height of tooth	10mm
 - or
 - (b) A halyard consisting of not more than two parts of rope or rope/wire combination, with no more than two single sheave blocks, to obtain no more than a double "Purchase" plus one hole or one eye, and one cleat which are fastened on the mast. The way of attaching the blocks on the lower end of the sprit or on the mast is optional. The sprit shall not be adjustable from aft of the mid-ship frame.
- 3.5.5.4 Outhaul. The outhaul shall be made of rope, and consist of a single material. It may be adjustable. In this case it shall use no more than two purchases; no blocks are allowed; and the outhaul end shall then pass through the hole or lacing eye near the end of the boom (see also CR 3.5.3.5) and be secured to the outhaul cleat on the boom.
- 3.5.5.5 The use of wire is prohibited except for the boom downhaul, sprit halyard and strops on the boom for fitting sheet blocks.
- 3.5.5.6 No running rigging shall be allowed inside of hollow spars.

4 ADDITIONAL RULES

- 4.1 Only one person shall be on board while racing.
- 4.2
- (a) The helmsman shall wear adequate personal buoyancy. All fastening devices supplied by the manufacturer shall be used in the manner intended. Wet suits and dry suits do not constitute personal buoyancy.
 - (b) With reference to the Racing Rules of Sailing the total weight of clothing and equipment worn or carried by a competitor, excluding footwear shall not be capable of exceeding 8kg when weighed as provided in Appendix J of the Racing Rules.
 - (c) Hiking pants, not attached to the boat and not containing any stiffening which can extend below the knee joint, are permitted irrespective of whether they would otherwise contravene RRS 49.1.
- 4.3 The following equipment shall be on board while racing:
- (a) One or more bailers which shall be securely attached to the hull by a lanyard(s). One bailer shall have a minimum capacity of one litre.
 - (b) A painter of a single piece of buoyant rope, not less than 5mm diameter and not less than 8m long securely fastened to the mast thwart or mast step. (see also 3.2.6.1)
- 4.4 An anchor need be carried only when specifically prescribed in the sailing instructions.
- 4.5 A paddle, secured to the hull, need be carried only when prescribed in the sailing instructions.
- 4.6 Unless damage renders a sail unusable during an event, only one sail shall be used throughout any series of races. Any such change of sail shall be authorised by the protest committee.
- 4.7 If there is a national Optimist Class Association of the country in which the boat is registered the owner shall be a member.

6 **SAIL**

6.1 General

- 6.1.1 Anything not specifically permitted by these rules is prohibited, see also CR. 1.2.
- 6.1.2 *Sails* shall be made and measured in accordance with the current ISAF "Equipment Rules of Sailing" as applicable to Optimist sails, except where varied herein. Where a term defined or measurement given in these ISAF Rules is used in these rules, it is printed in "italic" type. All measurements shall be taken along the surface of the *sail* and include any bolt rope and *tabling*. *Battens* shall not be removed for sail measurement purposes.
- 6.1.3 The manufacturer of *sails* is optional.
- 6.1.4 The thickness in mm of the *body of the sail* shall be indelibly marked by the manufacturer, together with his signature, stamp, and date near the *peak point*. The thickness of the woven *ply* of the *body of the sail* (finished product) shall be checked according to ISAF current instructions.
The thickness of the *body of the sail* shall be not less than 0.15mm. Applies to *sails* first measured after 1 March 1994. Thinner *sails* shall cease to comply with this Class Rule on 1 March 1996.

6.2 Mainsail

6.2.1 Construction

- 6.2.1.1 The construction shall be: *soft sail, single ply sail*.
- 6.2.1.2 The *body of the sail* shall consist of the same woven *ply* throughout. The *ply* fibres shall be of polyester or cotton.
- 6.2.1.3 The *sail* shall have two *battenpockets* in the leech. Local widening for *batten* insertion (if any) shall be on the upper edge of the *batten pockets*.
- 6.2.1.4 The following are permitted: stitching, glues, bolt ropes, *batten pocket* elastic, one trapezoidal *window*, *sail* maker label, *sail* button(s), tell tales.
Reinforcements shall be of the same woven *ply* as the *body of the sail*. *shall be fixed by a maximum of two lines of stitches or bonding agents*. Parallel or nearly parallel lines of stitching or bonding agent used elsewhere in the *secondary reinforcement* shall be more than 40mm apart. If two rows of closely positioned stitching are used to fix the edge of the *secondary reinforcement* then any inner lines of parallel stitching shall be more than 40mm distant from the inner line of edge stitching.
Further to CR. 1.2 and 6.1.1, the following are prohibited: carbon fibres, titanium.
- 6.2.1.5 Wire or elastic cord shall not be used in the *sail*. Any bolt rope or *tabling* used to strengthen the *luff* or *head* of the *sail* shall be fastened to the *sail* throughout its entire length. If a bolt rope is enclosed in the *tabling*, it shall be sewn to the *sail* by visible stitches at those corners of the *sail* to which the rope extends.
- 6.2.1.6 On *sails* first measured after 1 March 1994 there shall be 8 eyelets in the *foot* of the *sail*, including those at the *tack* and *clew*.
On *sails* first measured after 1 March 1994 there shall be 8 eyelets in the *luff* of the *sail*, including those at the *throat* and *tack*.
(See also CR. 6.2.2 for spacing between eyelets in *luff* and *foot*.)

6.2.2 Dimensions

		minimum	maximum
1	<i>Leech length</i>	-	2800 mm
2	<i>Head length</i>	-	1240 mm
3	<i>Diagonal</i>	2450 mm	2580 mm
4	<i>Half width</i>	-	1700 mm
5	<i>Foot median</i>	-	2130 mm
6	<i>Luff length</i>	-	1730 mm
7	Width of <i>luff</i> measurement band	5 mm	-
8	Length of <i>luff</i> measurement band	60 mm	-
9	Upper edge of <i>luff</i> measurement band to <i>throat point</i>	-	600 mm
10	Thickness of <i>woven ply</i> anywhere in the <i>body of the sail</i>	0.15 mm	-
11	<i>Primary reinforcements:</i> from corner measurement points	-	205 mm
12	<i>Secondary reinforcements:</i> from corner measurement points	-	615 mm
13	<i>Batten pocket patches</i> at each end of <i>batten pockets</i>	-	150 mm
14	<i>Flutter patches</i>	-	150 mm
15	<i>Tabling width</i>	-	40 mm
16	<i>Seam width</i>	-	15 mm
17	Trapezoidal <i>window opening area</i>	-	0.1 m ²
18	Shortest distance from <i>window</i> to any edge of <i>sail</i>	150 mm	-
19	<i>Batten pocket length</i> (outside)	-	460 mm
20	<i>Batten pocket width</i> (outside)	-	40 mm
21	<i>Peak point</i> to intersection of <i>leech</i> and lower edge of uppermost <i>batten pocket</i>	900 mm	1000 mm
22	<i>Peak point</i> to intersection of <i>leech</i> and lower edge of lowermost <i>batten pocket</i>	1850 mm	1950 mm
23	Space between <i>luff</i> eyelets	230 mm	260 mm
24	Space between <i>foot</i> eyelets	270 mm	300 mm
25	<i>Foot Irregularity</i>		15 mm

6.3 Spare number

6.4 Spare number

6.5 Class Insignia, National Letters and Sail Numbers, Luff Measurement Band

6.5.1 The class insignia, *sail* numbers and letters as issued by the National Authority shall be in accordance with current Racing Rules of Sailing, except where varied herein.

6.5.2 Numbers and letters on *sails* first measured after 1 March 1994 shall be of the following dimension (see also Sail Plan sheet 4/5)

		minimum	maximum
1	Height	230 mm	240 mm
2	Width (except "1" or "l")	150 mm	160 mm
3	Width for M and W	160 mm	170 mm
4	Thickness	30 mm	40 mm

The national letters shall be placed on the same line on opposite sides of the *sail* with letters on the starboard side of the sail closer to the luff than those on the port side of the sail (see also Sail Plan sheet 4/5). The numbers shall be placed in two rows below the letters with the starboard side numbers uppermost. The following spacing shall apply

		minimum	maximum
5	Space between adjoining numbers or letters	40 mm	50 mm
6	Space between rows of numbers or letters	40 mm	50 mm
7	Space between the national letter groups on opposite sides of the <i>sail</i>	100 mm	150 mm
8	Distance between the <i>luff</i> and the closest letter or number in each row	150 mm	
9	Distance between lower edge of uppermost <i>batten pocket</i> and the national letter which is closest to the <i>leech</i>	40 mm	50 mm

6.5.3 The class insignia shall conform with CR. 2.7.1, and have dimensions and requirements as detailed in the Sail Plan sheet 4/5. On *sails* first measured after 1 March 1994 no part of the class insignia shall extend beyond 1000 mm of the peak point. The class insignia shall be placed back to back on both sides of the *sail*.

6.5.4 The *sail* shall have a *sail* measurement band on its *luff* (*luff* measurement band). This band, of a colour that strongly contrasts with the *sail*, shall be permanently fixed or marked on both sides of the *sail*. It shall be perpendicular to the edge of the *luff* of the *sail*, and shall start at its edge. See CR. 6.2.2, Sail Plan, Rigging Plan sheet 12/12, for position and dimension of bands.

6.6 Additional rules

6.6.1 Only *sails* endorsed in accordance with CR. 2.5.6 shall be used.

6.6.2 The manufacturer of *sail battens* is optional. The construction material is optional except that Carbon fibre is prohibited.

6.6.3 Fastening and positioning.

6.6.3.1 The upper edge of the *luff* measurement band shall not extend above the lower edge of Band No. 1, and the lower edge of the *luff* measurement band shall not extend below the upper edge of Band No. 2. At the *throat*, both mast holes or lacing eyes referred to in CR. 3.5.2.6 shall be used to prevent any part of the *luff* measurement band rising above the lower edge of Band No. 1.

6.6.3.2 No part of the *clew point* shall extend beyond the inner edge of the boom band.

6.6.3.3 The *luff* of the *sail* shall be lashed to the mast at each eyelet so as to be within 10 mm of the mast.

6.6.3.4 The *foot* of the *sail* shall be lashed to the boom at each eyelet so as to be within 10 mm of the boom. Alternatively, at the *tack* eyelet, it may either be lashed to the jaw fittings or attached through two holes in the jaws or jaw fittings, so as to be within 10 mm of the boom or its imaginary extension (see also Rigging Plan sheet 12/12).

6.6.3.5 The *sail* shall be fastened to the mast and boom with cordage only.

6.6.3.6 The *peak* of the *sail* shall be fastened to the upper end of the sprit either by means of an eyelet at the *peak*, or by means of a loop made of tape or rope sewn to the *peak*.

APPENDIX A

CLASS RULES SPECIFIC TO WOOD AND WOOD/EPOXY HULLS

- 2.5.1 Only a measurer officially recognised by a National Authority shall measure a hull, spars, sails and equipment, and sign the declaration on the measurement form that they comply with the class rules. Hulls shall be measured in accordance with the appropriate hull measurement instructions. After the measurer has signed the measurement form, he shall affix the ISAF plaque to the mast thwart bulkhead as per CR 2.7.2
- 2.5.4 All hulls shall comply with the current rules or the rules current at the time the boat was first measured. Hulls first measured between 1 March 1997 and 1 March 1998 shall conform either to the class rules in force from 1 March 1995 or the class rules in force from 1 March 1997. Hulls first measured after 1 March 1998 shall conform to the class rules then current. Fittings, spars, sails and other equipment shall comply with the current rules unless otherwise stated in the specific class rule referring to such equipment.

3.2.1 Materials - WOOD AND WOOD/EPOXY

- 3.2.1.1 The hull shall be constructed of materials approved by the ISAF. The following are the currently approved materials: wood.
- 3.2.1.2 Hulls shall be constructed from:

Wood	
Commercially available plywood, of marine or other waterproof grade suitable for boatbuilding	Plywood of 6mm minimum nominal thickness and weighing not less than 2kg/m ² shall be used, except that thinner plywoods may be used for doubling pieces and in construction of the hull bottom. (see Plan sheets).
Glue - Epoxy resin for bonding	
Glass tape and metal fasteners	

The builder shall on request supply a sample and specification sheet of any plywood used.

- 3.2.2.1 The dimensions of the hull shall be as shown on the plans and as given in these rules, diagrams and measurement form and shall conform with the tolerances stated therein.
- 3.2.2.5 The overall length excluding rudder fittings, shall be 2300mm +/- 12mm, measured at the sheerline.
- 3.2.2.9 The forward and aft transom shall be flat with not more than 5mm tolerance.
- 3.2.2.10 The inside of the daggerboard case and of the slot in the hog and bottom panel shall be 330mm +/- 5mm. The ends in the daggerboard case slot shall be parallel and square to the base line. A rake to taper not exceeding 5mm is permitted. The upper edge of the daggerboard case shall be parallel to the base line, with a tolerance of 5mm maximum.
- 3.2.2.11 The inside width of the daggerboard case and the slot in the hog and bottom panel shall be 17mm +/- 1mm. The fore and aft ends of the slot shall be semi-circular in cross section.

3.2.2.12 The outside edges of the hull between bottom and side panels, between the bottom and forward transom, and between the side panels and forward transom shall be rounded to a radius of 4+/-2mm. At the aft transom side and bottom outside edges no radius is permitted.

3.2.3 Wood and wood/epoxy Hull Construction Details

3.2.3.1 There shall be a mast thwart positioned as shown on the plan. It shall be 195mm +/- 5mm wide and not less than 16mm nor more than 25mm thick.

3.2.3.2 There shall be a mast thwart bulkhead fixed to the aft side of the mast thwart, and in wooden hulls to the side pieces secured to the side panels, as shown on the plans.

3.2.3.3 There shall be a midship frame positioned as shown on the plans with limber holes in the positions shown.

3.2.3.4 The shape of the hole in the mast step is optional. (See also rule 3.2.6.1(f)).

3.2.4 **Construction Details - Wood**

3.2.4.1 Hulls of Traditional Wood Construction

- (a) The hog, bilge stringers and chine shall be of wood bonded to the inside of the bottom panel. they shall each be of uniform thickness and shall each be of uniform width:
 - (i) for the hog min 16 x 100mm min
 - (ii) for the bilge stringers chine and gunwale 16 x 35 mm min.
- (b) The scantlings for the frames, hog, stringers and chine shall be complied with but exposed corners, except for the gunwale (see rule (i) below), may be rounded to a maximum radius of 5mm.
- (c) not used in this version
- (d) not used in this version
- (e) The midship bottom frame and the daggerboard case sides shall be of plywood with a nominal thickness of 12mm.
- (f) As optional construction. the bow and aft transoms shall be of plywood with a nominal thickness of min. 6mm and max. 12mm.
- (g) The bottom and side panels, knees and mast thwart bulkhead shall be of plywood with a nominal thickness not less than 6mm.
- (h) The bottom and side panels shall each be of the same nominal thickness throughout.
- (i) The exposed edges of the gunwale stringer and the rubbing strake shall be rounded to a radius of not less than 5mm.
- (j) The knees at the transom may be inset so that their upper surfaces are level with the top of the gunwale stringers.
- (k) Exposed edges of plywood may be capped with solid wood or plywood. The depth of the capping shall not exceed the thickness of the plywood being covered and its width shall not exceed the width of the part of assembled parts being capped.

3.2.4.2 Hulls of Wood/Epoxy Construction

- (a) The hog and bilge stringers shall be of plywood bonded to the inside of the bottom panel. They shall each be of uniform thickness and shall each be of uniform width:
 - (i) for the hog not less than 180mm wide;

- (ii) for the stringers not less than 70mm wide, except forward of the mast thwart bulkhead where they may be tapered to conform to the shape of the bottom panels.
- (iii) the thickness of the bottom panel and hog or stringers together shall be not less than 15mm
- (b) Alternatively the bottom may be constructed of one or more sheets of plywood with a total uniform thickness of not less than 15mm. When such a construction is used, hog and stringers are not required.
- (c) The scantlings shown on the plans for the frames, hog and stringers shall be complied with but exposed corners, except for the gunwale(see rule (f) below), which may be rounded to a maximum radius of 5mm.
- (d) The bottom panel shall either be stitched to the side panels and transoms with copper wire at spacing of not more than 60mm, and/or glued with epoxy glue. The joints may be taped inside and/or outside with glass tape and resin.
- (e) Joints between midship frame and bottom panel, midship frame and the sides shall be taped with glass tape and resin or glued with epoxy glue fillets.
- (f) The midship bottom frame and the daggerboard case sides shall be of plywood with a nominal thickness of 12mm.
- (g) As optional construction. the bow and aft transoms shall be of plywood with a nominal thickness of min. 6mm and max. 12mm.
- (h) The bottom and side panels, knees and mast thwart bulkhead shall be of plywood with a nominal thickness not less than 6mm.
- (i) The bottom and side panels shall each be of the same nominal thickness throughout.
- (j) The exposed edges of the gunwale stringer and the rubbing strake shall be rounded to a radius of not less than 5mm.
- (k) The knees at the transom may be inset so that their upper surfaces are level with the top of the gunwale stringers.
- (l) Exposed edges of plywood may be capped with solid wood or plywood. The depth of the capping shall not exceed the thickness of the plywood being covered and its width shall not exceed the width of the part of assembled parts being capped.

PLANS - The following are the current official plans: (Wood and GRP)

New 95 GRP plans	March 1995 Amended March 1996
Traditional Wooden Plans Wood/Epoxy Plans	March 1997 March 1997
Rigging Plan	March 1991 Amended 1994
Foil Plan	March 1992 Amended 1994
Sail Plan	March 1994

© 2001 ISAF Limited

Effective: 1 March 2001
Last Issue: 1 March 1997

SAIL PLAN INDEX

(pp 28 - 32)

- 28 General dimensions
- 29 Material, reinforcements and batten-pockets
- 30 Window, tabling, bolt-ropes and eyelets
- 31 Sail numbers, insignia and button
- 32 Positioning measurement band

**ALL MEASUREMENTS IN MILLIMETRES
DIAGRAMS NOT TO SCALE**

GENERAL DIMENSIONS

Sails shall be made and measured in accordance with the current ISAF Equipment Rules of Sailing, unless modified by the Class Rules

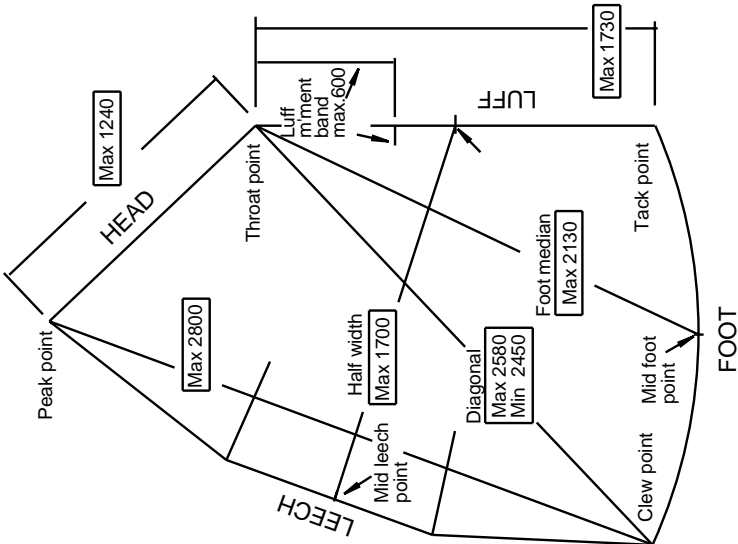

Corner measurement points

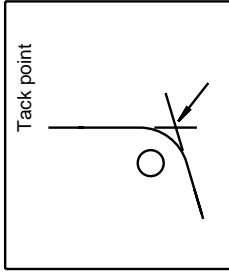
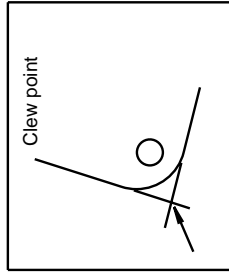
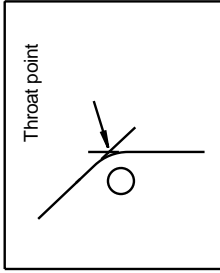
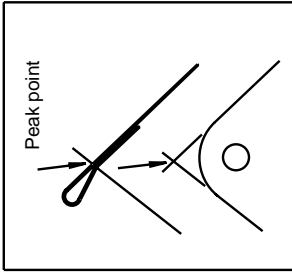

MATERIAL, REINFORCEMENTS & BATTEN POCKETS

Rules 6.1, 6.2, 6.6.2

The body of the single-ply soft-sail shall consist of the same woven ply throughout. The minimum thickness of the woven ply anywhere in the body of the sail shall be not less than 0.15mm. The ply fibres shall be of polyester or cotton.

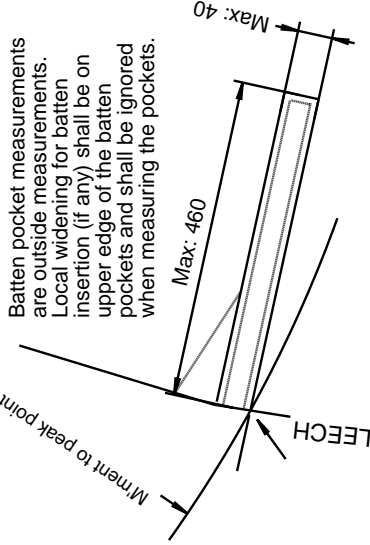
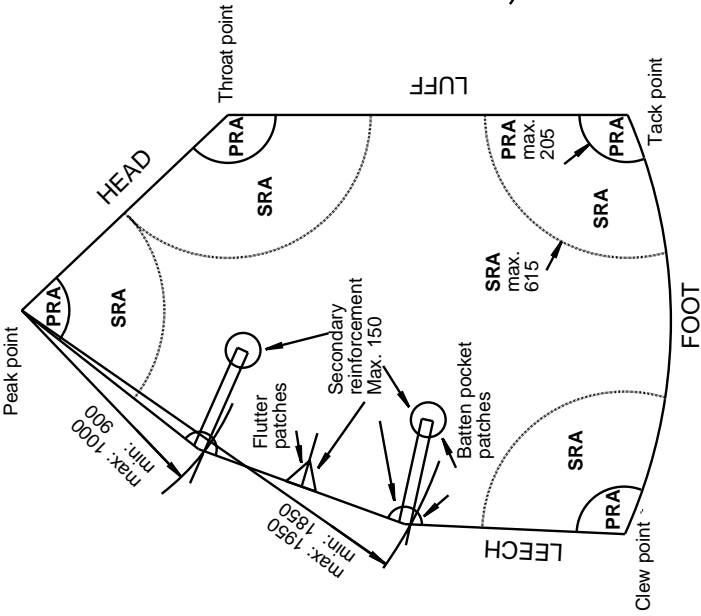

Battens shall not be removed for measurement purposes

PRA = Primary Reinforcement Area.
SRA = Secondary Reinforcement Area. (Rule 6.2.1.5; 6.2.2)

INTERNATIONAL OPTIMIST	Sail Plan sheet: 2/5	Date: March 1994
This plan shall be read in conjunction with the latest Class Rules ©1994 International Yacht Racing Union		

WINDOWS, SEAMS, TABLING, BOLT ROPES, EYELETS. Rule 6.2

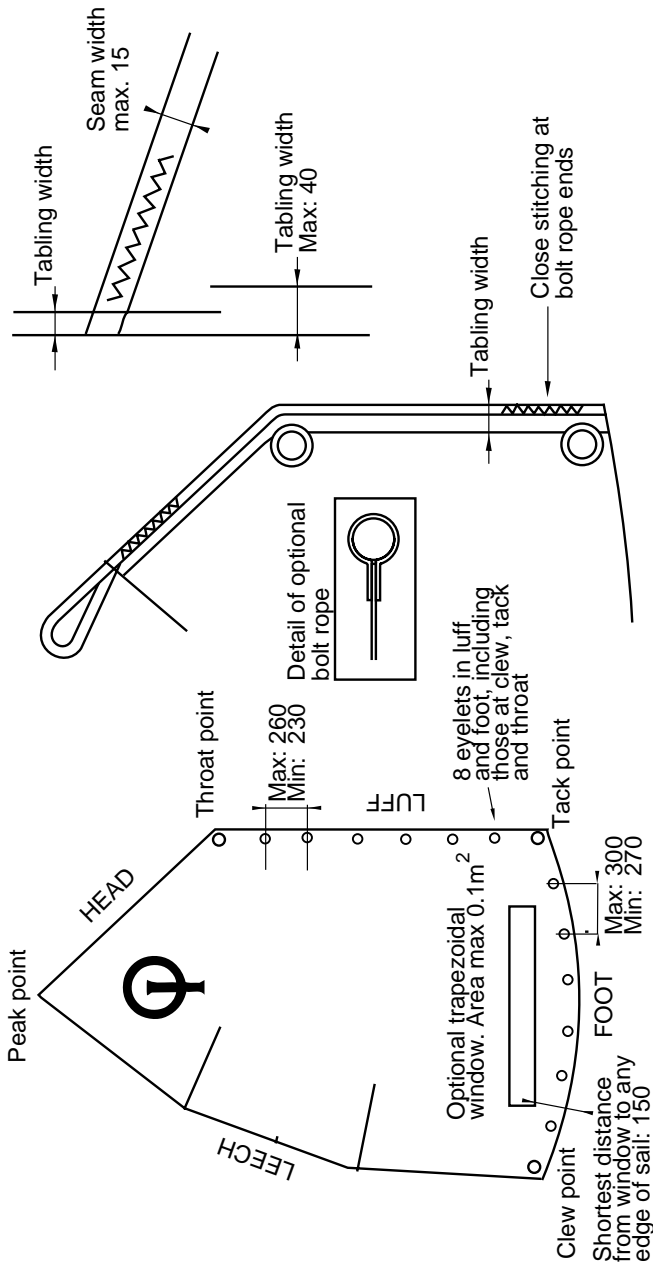

SAIL NUMBERS, INSIGNIA & BUTTONS. Rule 6.5

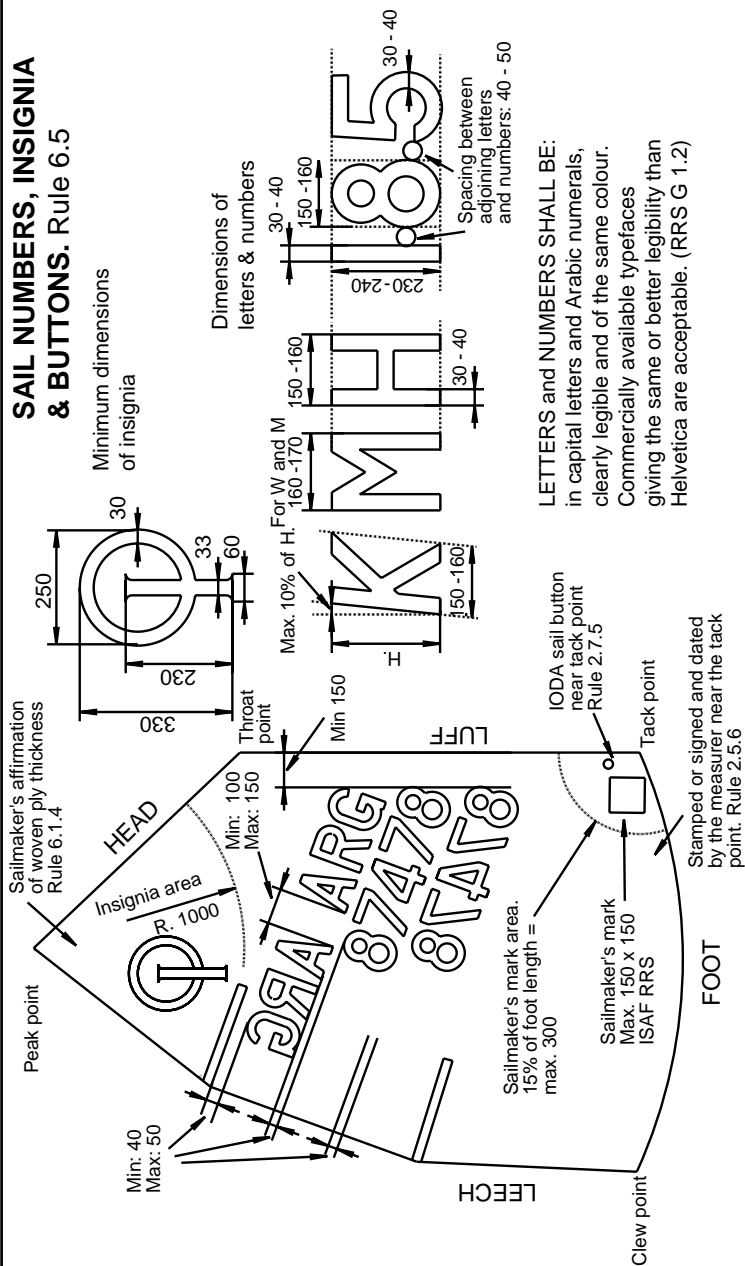

LETTERS and NUMBERS SHALL BE:
 in capital letters and Arabic numerals,
 clearly legible and of the same colour.
 Commercially available typefaces
 giving the same or better legibility than
 Helvetica are acceptable. (RRS G 1.2)

INTERNATIONAL OPTIMIST	Sail Plan sheet: 4/5	Date: March 1994
This plan shall be read in conjunction with the latest Class Rules © 1994 International Yacht Racing Union		

POSITIONING, LUFF MEASUREMENT BAND

Rules 6.5.4; 6.6.3.1; 3.5.2.7

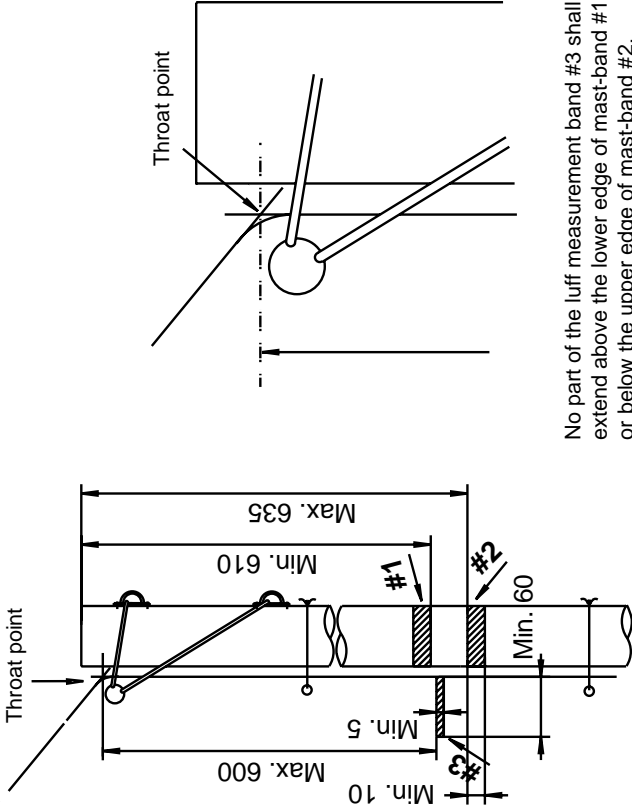

Measurement bands shall be distinctively coloured and clearly visible. Bands #1 and #2 around the mast. Band #3 (luff measurement band) shall strongly contrast with the sail and shall be permanently fixed or marked on both sides of the sail. Rules 6.5.4; 3.5.2.7

No part of the luff measurement band #3 shall extend above the lower edge of mast-band #1 or below the upper edge of mast-band #2.

INTERNATIONAL OPTIMIST	Sail Plan sheet: 5/5	Date: March 1994
This plan shall be read in conjunction with the latest Class Rules ©1994 International Yacht Racing Union		